

# Application of the Simulation Based Reliability Analysis on the LBB methodology

L. Pečínka<sup>a</sup>, M. Švrček<sup>a,\*</sup>

<sup>a</sup>Nuclear Research Institute Řež plc, Husinec-Řež 130, 250 68 Husinec, Czech Republic

Received 24 August 2008; received in revised form 10 October 2008

---

## Abstract

Guidelines on how to demonstrate the existence of Leak Before Break (LBB) have been developed in many western countries. These guidelines, partly based on NUREG/CR-6765, define the steps that should be fulfilled to get a conservative assessment of LBB acceptability. As a complement and also to help identify the key parameters that influence the resulting leakage and failure probabilities, the application of Simulation Based Reliability Analysis is under development. The used methodology will be demonstrated on the assessment of through wall leakage crack stability according R6 method. R6 is a known engineering assessment procedure for the evaluation of the integrity of the flawed structure. Influence of thermal ageing and seismic event has been elaborate.

© 2008 University of West Bohemia in Pilsen. All rights reserved.

*Keywords:* reliability analysis, R6 method, piping system

---

## 1. Introduction

The deterministic LBB requirements are as follows:

- postulate a leaking through wall crack at all weldments (at the chosen assessment location),
- crack size is chosen to get leakage which is 10 times higher than the detection limit,
- calculate the critical crack size using the normal operating conditions and the worst loading case (SSE or transients), check the safety margins,
  - margin between the calculated critical crack size and the postulated leakage crack size should be at least 2,
  - the calculated leakage crack should be stable using a load which is 1.4 times higher than the load used to calculate the critical crack size. Usually the R6, LBB NRC or MPA/KWU methodologies are applied.

On the other hands probabilistic tools are essential to highlight effect of uncertainties around the deterministic criteria of safety analyses. In this paper, the Simulation Based Reliability Analysis is applied to calculate stability of postulated leakage crack using R6 method [1].

---

\*Corresponding author. Tel.: +420 226 172 308, e-mail: smi@ujv.cz.

## 2. Principles of the simulation based reliability analysis

The reliability methods were introduced in very late seventies both in industry and nuclear energy. Two traditions exist: Nuclear industry is based on PSA/PRA methodology while industry is based on Structural Reliability Assessment. Basic differences may be specified as follows (Table 1).

Table 1. Basic differences PSA and SRA methodologies

PSA	SRA
– P by fault trees	– P by $g(x) < 0$
– Relies on failure data	– Relies on material and loads data and models
– Frequentistic Probability	– Bayesian Probability
– Best Estimates	– All uncertainties included
– Uncertainties not included	– Sensitivity of Probabilities
– Uncertainties in results	– Subjective Probability
– Objective probability	– Dependencies is easy to model
– Weak on Dependencies	

A decision making to include piping systems in PSA is based on the assessments of the relative importance of system failures to plant safety and pipe failure contribution to system failure. That is “what are the potential consequences of a piping failure”? As examples: “Can a piping failure result in a common cause failure of a several safety systems?” “In cases of major leakage or rupture, can affected piping section be isolated to prevent further damage?” An existing PSA provides necessary information through application of suitable importance measures and screening steps using the “Reliability Influence Matrices”.

The design of safety related (Class 1) piping systems of nuclear power plants is based on the requirements of the ASME Code Section III, Article NB and on the US NRC Standard Review Plan, Chapter 3.6.2 (Break Postulations) and 3.6.3 (Leak-Before-Break). This approach is fully deterministic. The Probabilistic Reliability Assessment Procedure is based on the Limit States Philosophy. Two main groups of reliability functions can be established:

- Ultimate (safety) Limit State (ULS) functions applied in case of piping integrity assessment correspond to load bearing resistance (including structural durability affected by accumulation of damage and time dependent load effects combination),
- Serviceability Limit State (SLS) functions refer to authority requirements and other particular service requirements.

The reliability conditions can be expressed formally in several ways as indicated in [2]. Fig. 1a illustrates the arrangement most frequently found in standards to express the strength conditions. By use of a transformation model (TM-1), the designer converts loads into load effects  $S$  considering the structural model. An example is the analysis of a structure under the action of the loads to determine the axial forces, shears and moment acting at all cross section to be investigated. Another transformation model (TM-2) serves to establish the resistance (RV). The resistance is defined as the strength or the load bearing strength of a cross section,

component or member, or, in other words, as the ability to withstand actions without “Mechanical” failure or reaching a conventional state of reference (limiting value). Reference values are established using either theory, assumptions such as the amount of initial imperfection, or experimental evidence. The analysis of the reliability function  $RF = RV - S$  leads to determining the probability of failure  $P_1$  which is then compared to the target probability  $P_d$  to check if the reliability condition (RC) is satisfied.

Reliability conditions for which TM-2 models are not given in standards cannot be assessed by the method of fig. 1a and a more general format is therefore needed. Fig. 1b illustrates this approach. The general transformation model converts the loads not into load effects (bending moments, normal and shear forces, etc.) but into the response of the structure and its components, which may be expressed in terms of stresses, strains, deformations, load-deflection curves, accelerations, stress-range spectra, stress intensity factors, etc.

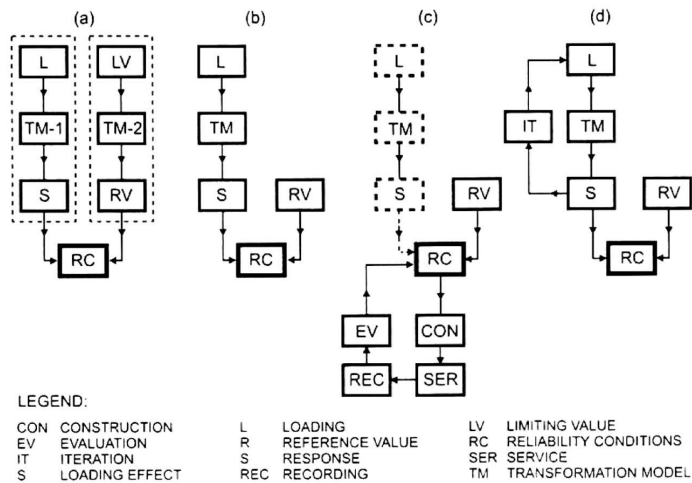

Fig. 1. Formal expression of reliability conditions

The designer performs this function and satisfies the reliability conditions by comparing the response to some (limiting) values of RV, obtained from experiments or other sources based on Limit States Design rules, fig. 1c illustrates the third approach, which may be used when there are substantial uncertainties in the loading and/or in the transformation model. The structure is built and assessed subsequently based on observations in service. The response history is then evaluated and used as feedback to assess the reliability conditions of the structure. Applications of this approach are often used in the assessment of structures exposed to fatigue damage. It may lead to the retrofitting of the existing structure and/or to an increase in general knowledge on fatigue loading. A subset of this procedure is used when load tests are used to assess the load bearing capacity of a structure.

Another approach suggests itself, as shown in fig. 1d in the case when the magnitudes of the loads depend on the deflection of the structure exposed to loading. Examples include the case of a roof that deflects due to the weight of rainwater, i.e. in case of so called liquefaction, or special cases of soil-structure interaction. The transformation model is used to determine the response for an initial set of loads and an iterative procedure is then required to find the response due to the change in loads on the structure deformed underneath it. When the response stabilizes, the probability of failure  $P_1$  can be calculated and the reliability condition  $P_1 < P_d$  checked.

Direct application of above described ways to LBB concept is as follows:

- Fig. 1a represents LBB requirements, since the load bearing capacity represent the conditions,
  - $l_{crit}/l_{leak} > 1$ ,
  - requirements for crack initiation and unstable crack growth,
- Fig. 1b represents “No Break Zone” or “Superpipe” concepts since calculated stresses are compared with allowable ones,
- Fig. 1c represents the leak detection systems which are based on the pattern recognition approach and on the storing and evaluation of trends,
- Fig. 1d represents ageing management problem in LBB. The LBB. NRC methodology is based on the  $J$  integral approach. It is well known that due to thermal ageing the value of  $J$  integral decreases. Iteration solution should be applied. Another case is the influence of non-repeated anchor movement if the building settlement increases step by step.

In the next, the application of fig. 1a scheme to R6 methodology and dissimilar weld is performed.

### 3. Input data

We will suppose that geometrical and material parameters as well as acting loadings have random character. For the demonstration the following input data were chosen according to [3]. Pipe diameter  $D = 245$  mm, flow stress  $\sigma_f = 367.3$  MPa,  $J$ -integral  $J_{0.2} = 85$  kJ/m<sup>2</sup>, work temperature  $T = 315$  °C, internal pressure  $P_{int} = 12.65$  MPa, external pressure  $P_{ext} = 0.1$  MPa, nominal bending moment  $M_{nom} = 3037$  Nm, nominal axial force  $F_{nom} = -433130$  N, seismic moment  $M_{SSE} = 44855$  Nm, seismic axial force  $F_{SSE} = 10084$  N, leakage crack size  $l_{leak} = 156.7$  mm and the following equations are valid:

$$\begin{aligned} F_{sup} &= F_{nom} + F_{SSE}, \\ M_{sup} &= M_{nom} + F_{SSE}. \end{aligned} \quad (1)$$

In the next, the deterministic analysis of the influence of the following parameters on the crack stability will be performed:

- through wall crack length  $l_{lead}$ ,
- $J_{0.2}$  integral,
- axial force  $F_{sup}$ .

In all cases, the uniform distribution functions have been chosen, see figs. 2–4.

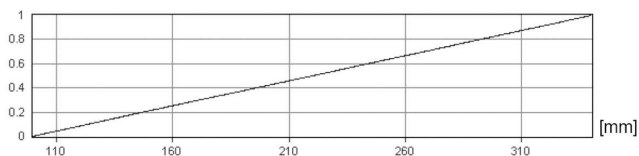

Fig. 2. Distribution function of the  $l_{leak}$

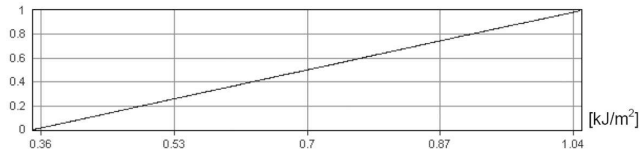

Fig. 3. Distribution function of the  $J_{0,2}$

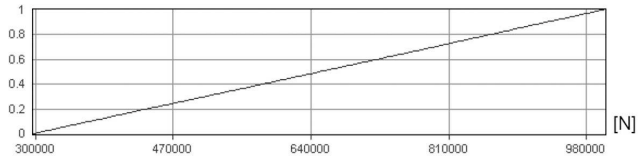

Fig. 4. Distribution function of the  $F_{sup}$

Results of performed simulations are illustrated in the fig. 5. Three different results were obtained.

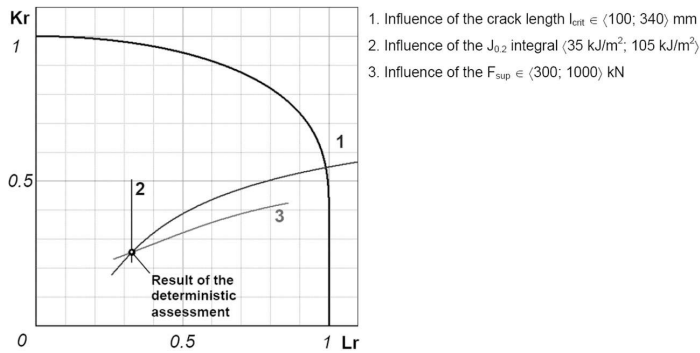

Fig. 5. Influence of the variable parameters on the crack stability

#### 4. Influence of the SSE on the crack stability

In the next, we will supposed that all acting loadings are random variable and independent each to other. The related histograms are illustrated in the figs. 6–12.

##### 4.1. Geometrical parameters

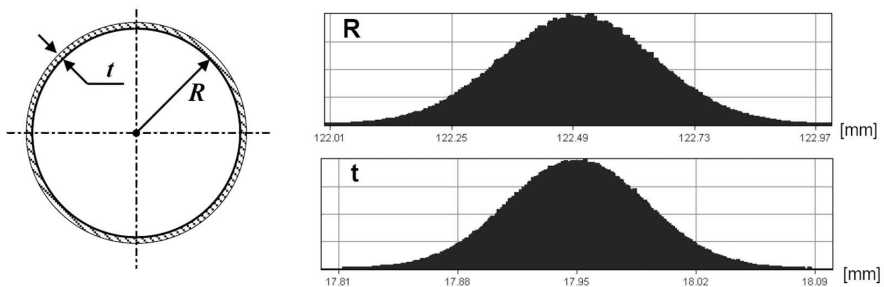

Fig. 6. Histograms of piping geometrical parameters

#### 4.2. Material parameters

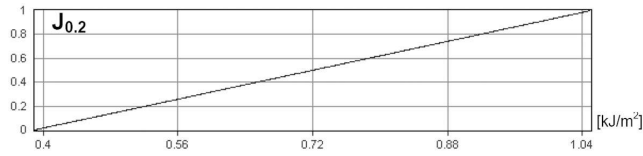

Fig. 7. Histograms of the flow stress  $\sigma_f$

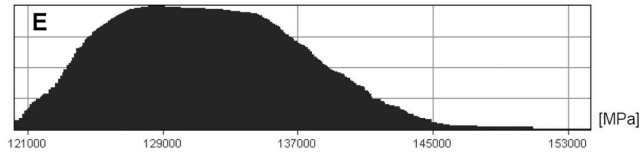

Fig. 8. Histogram of the Young modulus  $E$  of dissimilar weld

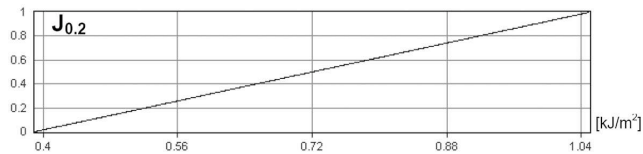

Fig. 9. Distribution function of the  $J_{0,2}$  integral

#### 4.3. Loadings

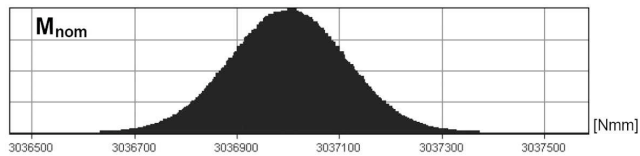

Fig. 10. Histogram of the static moment  $M_{nom}$

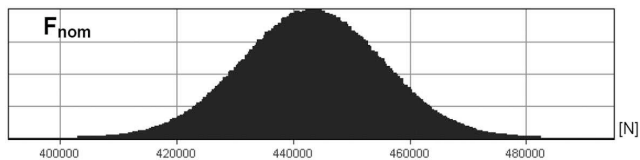

Fig. 11. Histogram of the static axial force  $F_{nom}$

In the next, fig. 12 illustrates seismic loadings  $F_{SSE}$  and  $M_{SSE}$ . The diagrams describing duration of loading are depicted. It is evident that there exists a significant region where these loadings do not exist and only a very narrow region ( $\sim 2\%$ ) where the loadings are non-zero.

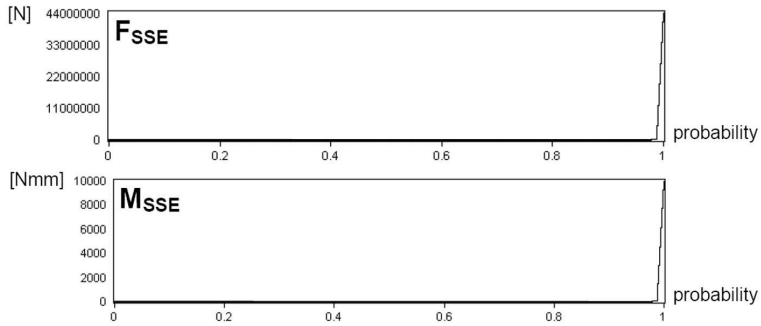

Fig. 12. Diagrams of duration time of seismic loading

The computed code Anthill<sup>TM</sup> has been used for generation of  $L_r$  and  $K_r$  histograms [4].  $L_r$  is relationship between stress value  $\sigma$  and critical stress value  $\sigma_C$ . And  $K_r$  is scale of pre-disposition to brittle fracture.  $10^7$  simulation steps have been performed. The vector of input values as random variables has been generated in each step and then the output values  $L_r$  and  $K_r$  post-calculated. Results are illustrated in the figs. 13 and 14.

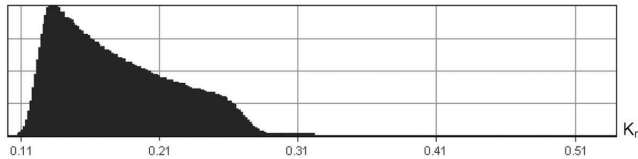

Fig. 13. Histogram of the  $K_r$  value  $K_r = \frac{K_I}{K_{IC}}$  [5]

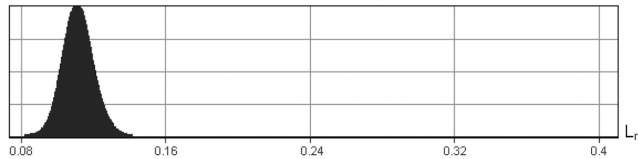

Fig. 14. Histogram of the  $L_r$  value  $L_r = \frac{\sigma}{\sigma_C}$

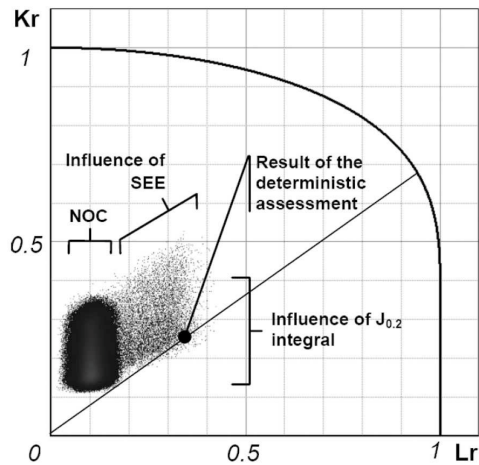

Fig. 15. The “Anthill” diagram

The resulting  $K_r - L_r$  diagram is illustrated in fig. 15, where all steps of simulation are depicted. The resulting interaction areas are called “Anthill”. Three different regions may be identified:

- first one for normal operation conditions (NOC),
- second one for SSE event,
- third one for changes of  $J_{0,2}$  values (ageing).

### 5. Assessment of probability of non-stabile crack grow

Depending on the materials condition, failure of the component can take any form from brittle fracture to fully plastic deformation. Transition between this two extreme points being assumed to be continous. On the basis of the Dugdale-Berenblatt model [1], the limit curve was defined as follows:

$$K_r = L_r \left\{ \frac{8}{\pi^2} \ln \left[ 1 / \cos \left( \frac{\pi}{2} L_r \right) \right] \right\}^{1/2}. \quad (2)$$

Only simulation steps resulting in the points out of limiting curve are important for this assessment. Application of standard equation (2) is non-effective since the values  $L_r > 1$  representing plastic collapse cannot be included. The following approach consists in transformation of equation (2) in the form:

$$-\frac{\pi^2 K_r^2}{8 L_r^2} = \ln \left[ \cos \left( \frac{\pi}{2} L_r \right) \right], \quad (3)$$

$$-\exp \left[ -\frac{1}{8} \left( \pi \frac{K_r}{L_r} \right)^2 \right] + \cos \left( \frac{\pi}{2} L_r \right) = 0. \quad (4)$$

The relation between each simulation step  $L_{ri}$ ,  $K_{ri}$  and the related point on the limit curve  $L_{ri}^I$ ,  $K_{ri}^I$  are illustrated in the next fig. 16.

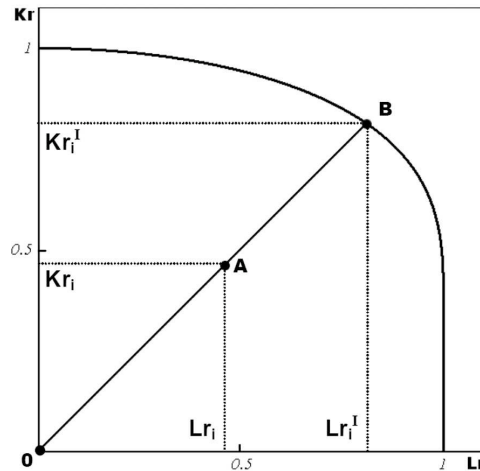

Fig. 16. Assessment of the safety coefficient



$$\frac{K_{ri}}{L_{ri}} = \frac{K_{ri}^I}{L_{ri}^I}. \quad (5)$$

Putting eq. (5) into eq. (4) and after rearrangement as the result we obtain

$$L_{ri}^I = \frac{2}{\pi} \arccos \left[ \exp -\frac{1}{8} \left( \pi \frac{L_{ri}}{K_{ri}} \right)^2 \right]. \quad (6)$$

Relating value  $K_{ri}^I$  may be written in the form

$$K_{ri}^I = L_{ri}^I \frac{K_{ri}}{L_{ri}}. \quad (7)$$

Reliability function  $F$  depends on geometrical parameters, material properties and the through wall crack length and takes the form

$$F = \frac{|OB|}{|OA|}, \quad (8)$$

where

$$|OA| = \sqrt{K_{ri}^2 + L_{ri}^2}, \quad |OB| = \sqrt{(K_{ri}^I)^2 + (L_{ri}^I)^2}.$$

The reliability function is calculated for each step of simulation. The  $i = N_C$  simulation steps have been performed. The resulting histogram of safety function  $F$  is illustrated in fig. 17.

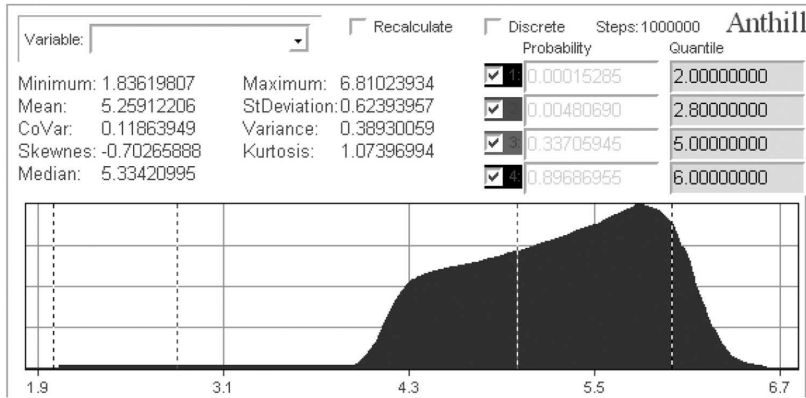

Fig. 17. Histogram of the reliability function  $F$

It is evident from the fig. 16 that the sufficient and necessary condition for the non-stable crack propagation takes the form

$$F = \frac{|OB|}{|OA|} < 1. \quad (9)$$

If the condition  $F = 1$  is met position of the points then the  $K_{ri}, L_{ri}$  are just on the limiting curve. The condition  $F > 1$  represents stability region under limiting curve.

The assessment of probability of non-stable crack propagation is based on the equation

$$P_f = \frac{N}{N_C}, \quad (10)$$

where  $N_C$  is total number of simulation steps and  $N$  is number of steps where inequality  $F < 1$  (eq. (9)) has been met.

## 6. Conclusion

As mentioned in Chapter 4,  $10^7$  simulation steps have been performed. From the safety function histogram (fig. 17) it is evident that not once step the condition  $F < 1$  has been met. It means that the probability of non-stable crack propagation is less than  $10^{-7}$ . In the 0.5 % of simulation steps the value of safety function is lesser than 2.8 (result of deterministic assessment in [3]). In the 0.015 % the condition  $F < 2$  has been met, see Chapter 1.

This paper represents the second step of NRI Řež plc effort to implement the reliability method in LBB methodology. Results of the first step were presented on the OECD-NEA workshop in Lyon, September 2006 [7].

It is evident that the Simulation Based Reliability Analysis is essential to highlight of uncertainties around the deterministic criteria of safety analyses, in particular for structural integrity not only piping systems. We will continue in our effort in future.

## Acknowledgements

Activities in this study are performed as a part of Research and Development Project No FT-TA4/083 programme TANDEM.

## References

- [1] K. Ikonen, H. Raiko, R. Keskinen, Leak Before Break Evaluation Procedures for Piping Components, Finnish Center for Radiation and Nuclear Safety, Helsinki, 1995.
- [2] P. Marek, J. Brozzeti, M. Guštar, P. Tikalsky, Tereco-Probabilistic Assessment of Structures using Monte Carlo Simulations, Academy of Sciences of CR, Institute of Theoretical and Applied Mechanics, Second Edition, Prague, 2003.
- [3] P. Samohýl, The LBB Evaluation of the Medsamor Unit 2 NPP, Report NRI Řež plc, DITI 301/199, December 2003.
- [4] Windows help file of program Anthill™ 2.5.0.1 Professional
- [5] A. Zahoor, Ductile Fracture Handbook, Vol. 1, EPRI 1989.
- [6] M. Vlk, Z. Florian, Limiting States and Reliability, Technical University Brno, Dept. of Mechanics, Mechatronic and Biomechanic, 2007 — In Czech language only.
- [7] OECD-NEA/IAGE: CSNI Workshop on: Structural Reliability Evaluation and Mechanical Probabilistic Approaches of NPP Components, Lyon, France, September 25–27, 2006.