

# Thick-walled anisotropic elliptic tube analyzed via curvilinear tensor calculus

T. Mareš<sup>a,\*</sup>

<sup>a</sup>Department of Mechanics, Faculty of Mechanical Engineering, Czech Technical University in Prague, Czech Republic, Technická 4,  
166 07 Prague

Received 3 September 2007; received in revised form 3 October 2007

## Abstract

After a brief introduction into the tensor calculus, the thick-walled anisotropic elliptic tube is analyzed. A procedure of the analysis is described in a stepwise manner. A choice of the appropriate coordinate systems is the first step. The second step consists of the determination of corresponding metric tensors. Then the elasticity tensor of a local orthotropy is transformed into a global computational coordinate system. Next the appropriate Christoffel symbols of the second kind are determined and the total potential energy of the system is expressed. At the end the solution is approximated by a Fourier series and for given geometrical values and loading the numerical results are obtained and graphically represented.

It must be said that throughout the calculation the free software only was used and for the numerical operations an old laptop is sufficient. The author regards both the former and the latter as a great advantage of the demonstrated method.

© 2007 University of West Bohemia. All rights reserved.

*Keywords:* anisotropic, tube, elliptic, curvilinear, tensor

## 1. Introduction

Elasticity is a branch of physics which studies the properties of materials that are deformed under stress (or, say, external forces), but then, when the stress is removed, return to its original shape. The amount of deformation is specified with strain, [2]. The concept of elasticity is build on the classical works of SIR WILLIAM PETTY (London, 1674) and ROBERT HOOKE (London, 1678/1660), and the state of an elastic body is characterized via stress and strain tensors, [9]. As it is, we must take a glance at the tensor calculus, [13], [10], [5], [6] and [4], and its most important tensor – the metric tensor,

$$g_{ab} = \frac{\partial \theta}{\partial \xi^a} \frac{\partial \theta}{\partial \xi^b},$$

$\theta$  being the radius vector of a point of the elastic body and  $\xi^a$  a curvilinear coordinate system, [8]. The contravariant metric tensor is defined as, [13], [10],

$$g^{ab} = (g_{ab})^{-1} \quad (1)$$

and the derivative of a vector as ( $\mathbf{g}_b$  being a vector base)

$$\frac{\partial \mathbf{a}}{\partial x^a} = \nabla_a a^b \mathbf{g}_b, \quad \nabla_a a^b = \partial_a a^b + \Gamma_{ac}^b a^c$$

\*Corresponding author. Tel.: +420 224 352 516, e-mail: tomas.mares@fs.cvut.cz.

where the Christoffel symbols of the second kind

$$\Gamma_{ab}^d = g^{dc} \frac{1}{2} (\partial_b g_{ac} + \partial_a g_{cb} - \partial_c g_{ab}), \quad \partial_a = \frac{\partial}{\partial x^a}.$$

The well known Differential operators are expressed as, [10], [8], [14], [15],

$$\begin{aligned} \text{grad } \varphi &= \nabla_a \varphi \mathbf{g}^a = \partial_a \varphi \mathbf{g}^a, \quad \text{div } \mathbf{v} = \nabla \mathbf{v} = \nabla_a v^a, \\ \text{rot } \mathbf{A} &= \nabla \times \mathbf{A} = \epsilon^{abc} \nabla_a A_b \mathbf{g}^c, \quad \nabla^2 \varphi = \text{div grad } \varphi. \end{aligned}$$

Let us state the definition of the Green-Lagrange-St. Venant strain, [1], [8], [4],

$$E_{ab}^\xi = \frac{1}{2} (g_{ab}^\xi - g_{ab}^o),$$

where  $g_{ab}^\xi$  is a metric of the material coordinate system coincident before the deformation with the space coordinate system  $g_{ab}^o$ .

For small deformations the Green-Lagrange-St. Venant strain takes the form of the small strain tensor, [9], [16], [14],

$$\varepsilon_{ab} = \frac{1}{2} (g_{ab}^\xi - g_{ab}^o) \Big|_{\text{lin.}} = \frac{1}{2} (\nabla_a u_b + \nabla_b u_a).$$

It became commonly known and used, [12], [16], [10], [7], [3],<sup>1</sup> that the real state of a deformed body,  $\hat{u}_a$ , minimizes the total potential energy

$$\Pi(u_a) = a(u_a) - l(u_a)$$

on a set of admissible states,  $\mathbb{U}$ , where the elastic strain energy

$$a(u_a) = \frac{1}{2} \int_{\Omega} E^{abcd} \varepsilon_{ab}(u_a) \varepsilon_{cd}(u_a) d\Omega$$

and the potential energy of the applied forces

$$-l(u_a) = - \int_{\Omega} p^a u_a d\Omega - \int_{\partial_t \Omega} t^a u_a d\Gamma.$$

Shortly, it holds

$$\hat{u}_a = \arg \min_{u_b \in \mathbb{U}} \Pi(u_c).$$

In the case of orthotropic material, for example orthotropic elementary block (signed as  $\nu$ th block, as outlined in Figure 1) we may choose the coordinate system,  $\nu_a$ , called the main

<sup>1</sup>The origin of these principles is joined with such names as MAUPERTUIS, 1746, EULER, 1744, and LAGRANGE, 1788.

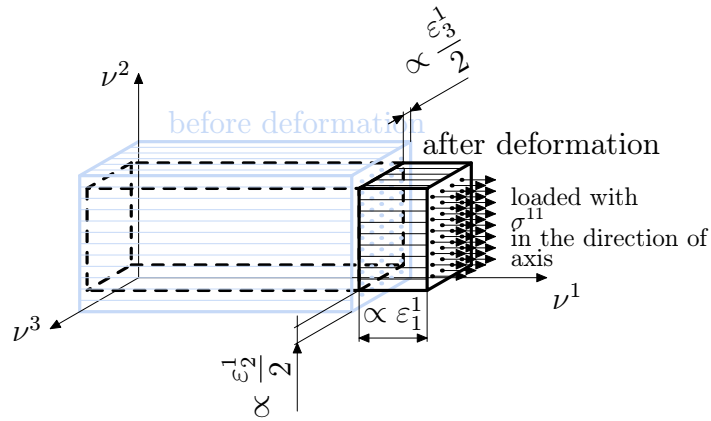

Fig. 1. Orthotropic block

material frame. The *main* stand for *alined with* the major material axes of the orthotropic material. Then the elasticity tensor has the following entries, [11],

$$\left\{ E^{abcd} \right\}_{\{ab|cd\}} = \begin{pmatrix} \Phi_{1111} & 0 & 0 & 0 & \Phi_{1122} & 0 & 0 & 0 & \Phi_{1133} \\ 0 & G_{12} & 0 & G_{12} & 0 & 0 & 0 & 0 & 0 \\ 0 & 0 & G_{13} & 0 & 0 & 0 & G_{13} & 0 & 0 \\ 0 & G_{12} & 0 & G_{12} & 0 & 0 & 0 & 0 & 0 \\ \Phi_{2211} & 0 & 0 & 0 & \Phi_{2222} & 0 & 0 & 0 & \Phi_{2233} \\ 0 & 0 & 0 & 0 & 0 & G_{23} & 0 & G_{23} & 0 \\ 0 & 0 & G_{13} & 0 & 0 & 0 & G_{13} & 0 & 0 \\ 0 & 0 & 0 & 0 & 0 & G_{23} & 0 & G_{23} & 0 \\ \Phi_{3311} & 0 & 0 & 0 & \Phi_{3322} & 0 & 0 & 0 & \Phi_{3333} \end{pmatrix},$$

where

$$\begin{aligned} \Phi_{1111} &= \frac{1 - \nu_{23}\nu_{32}}{N} E_{11}, & \Phi_{1122} &= \frac{\nu_{21} + \nu_{23}\nu_{31}}{N} E_{11}, & \Phi_{1133} &= \frac{\nu_{31} + \nu_{32}\nu_{21}}{N} E_{11}, \\ \Phi_{2211} &= \frac{\nu_{12} + \nu_{13}\nu_{32}}{N} E_{22}, & \Phi_{2222} &= \frac{1 - \nu_{13}\nu_{31}}{N} E_{22}, & \Phi_{2233} &= \frac{\nu_{32} + \nu_{31}\nu_{12}}{N} E_{22}, \\ \Phi_{3311} &= \frac{\nu_{13} + \nu_{12}\nu_{23}}{N} E_{33}, & \Phi_{3322} &= \frac{\nu_{23} + \nu_{21}\nu_{13}}{N} E_{33}, & \Phi_{3333} &= \frac{1 - \nu_{12}\nu_{21}}{N} E_{33}, \end{aligned}$$

and

$$N = 1 - \nu_{12}\nu_{21} - \nu_{23}\nu_{32} - \nu_{31}\nu_{13} - \nu_{12}\nu_{23}\nu_{31} - \nu_{13}\nu_{32}\nu_{21}.$$

The above relations may be readily used in a very large variety of anisotropic materials via the concept of locally orthotropic material.

The concept of locally orthotropic material is based on the thought that at every point of a material it is possible to construct a cartesian coordinate system  $\nu_a$  such that the material in (infinitesimal) surrounding behaves orthotropically, *i.e.*, the mentioned relations hold.

Thus we only need to perform a transformation from the main frame of orthogonality,  $\nu^a$ , into a frame of the computation. In the frame of the computation, the tensor entries are not necessarily physical quantities.

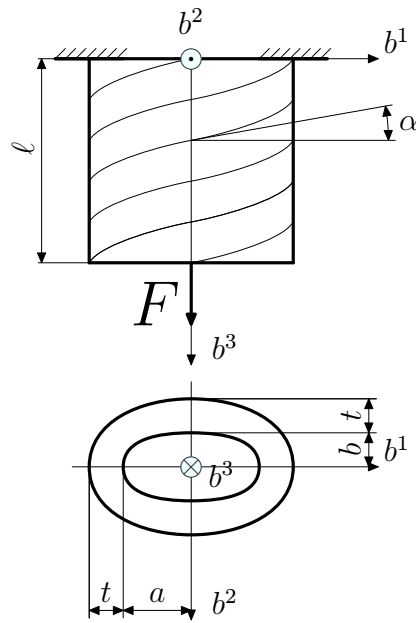

Fig. 2. The anisotropic elliptic tube

## 2. Analysis of the thick-walled anisotropic elliptic tube

Let us focus on the analysis of the deformation of a thick-walled elliptic tube which is wound of a fiber such as laminated composite (Fig. 2). The upper end of the tube is clamped and a uniformly distributed force,  $F$ , is applied on the lower end. The fiber is wound under an angle,  $\alpha$ . The problem is solved using the concept of locally orthotropic material, where the elasticity tensor is expressed in a local cartesian coordinate system aligned with the main directions of the local orthotropy of the material. A sequence of coordinate transformations from the local cartesian coordinate systems into a global coordinate system of the computation is performed. The total potential energy of the problem is expressed in the global coordinate system. After approximating the dependent variables, representing the displacements, with Fourier series, the potential energy expression is minimized.

As it has been said, the foremost task rests in a choice of appropriate coordinate systems and expression of the transformations. In the case of an elliptic tube wound under an angle we introduce, according to Fig. 3, the global cartesian coordinate system,  $b^a$ , the global elliptic coordinate system,  $x^a$ , the local cartesian coordinate system,  $\xi^a$ , and the local coordinate system aligned with the main directions of the local orthotropy,  $\nu^a$ . The basic advantage of the elliptic coordinate system lies in the range of the coordinates

$$x^1 \in [0, t], \quad x^2 \in [0, 2\pi], \quad x^3 \in [0, \ell]$$

and the known relation to the global cartesian coordinate system  $b^a$

$$b^1 = (a + x^1) \cos x^2, \quad b^2 = (b + x^1) \sin x^2, \quad b^3 = x^3.$$

As the coordinate systems  $b$ ,  $\xi$  and  $\nu$  are Cartesian, the metrics are

$$g_{ab}^b = \delta_{ab}, \quad g_{ab}^\xi = \delta_{ab}, \quad g_{ab}^\nu = \delta_{ab}.$$

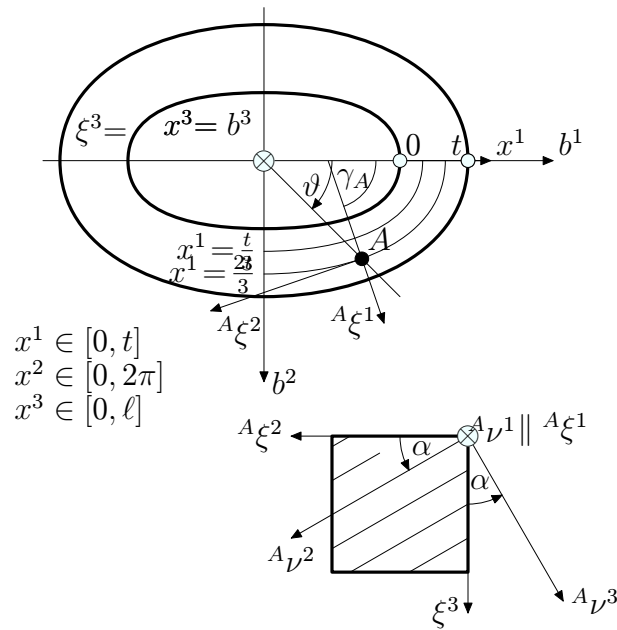

Fig. 3. Coordinate systems

The following transformation rule

$$g_{ab}^x = \frac{\partial b^c}{\partial x^a} \frac{\partial b^d}{\partial x^b} \delta_{cd} \text{ with } \frac{\partial b^a}{\partial x^b} = \begin{pmatrix} \cos x^2 & -(a + x^1) \sin x^2 & 0 \\ \sin x^2 & (b + x^1) \cos x^2 & 0 \\ 0 & 0 & 1 \end{pmatrix}_{a[b}$$

implies

$$g_{ab}^x = \begin{pmatrix} 1 & (b - a) \sin x^2 \cos x^2 & 0 \\ (b - a) \sin x^2 \cos x^2 & (a + x^1)^2 \sin^2 x^2 + (b + x^1)^2 \cos^2 x^2 & 0 \\ 0 & 0 & 1 \end{pmatrix}.$$

Elasticity tensor in the global computational coordinate system can be expressed via transformation rule

$$E^{abcd} = \frac{\partial x^a}{\partial \nu^i} \frac{\partial x^b}{\partial \nu^j} \frac{\partial x^c}{\partial \nu^k} \frac{\partial x^d}{\partial \nu^l} E^{ijkl \nu},$$

where  $E^{ijkl \nu}$  is the known elasticity tensor in the coordinate system  $\nu^a$ . For the transformation matrix it holds

$$\frac{\partial x^a}{\partial \nu^b} = \frac{\partial x^a}{\partial b^c} \frac{\partial b^c}{\partial \xi^d} \frac{\partial \xi^d}{\partial \nu^b},$$

where

$$\frac{\partial x^a}{\partial b^b} = \left( \frac{\partial b^a}{\partial x^b} \right)^{-1},$$

i.e.

$$\frac{\partial x^a}{\partial b^b} = \frac{1}{a \sin^2 x^2 + b \cos^2 x^2 + x^1} \begin{pmatrix} (b + x^1) \cos x^2 & (a + x^1) \sin x^2 & 0 \\ -\sin x^2 & \cos x^2 & 0 \\ 0 & 0 & a \sin^2 x^2 + b \cos^2 x^2 + x^1 \end{pmatrix},$$

$$\frac{\partial b^a}{\partial \xi^b} = \begin{pmatrix} \cos \gamma_A & -\sin \gamma_A & 0 \\ \sin \gamma_A & \cos \gamma_A & 0 \\ 0 & 0 & 1 \end{pmatrix} \text{ and } \frac{\partial \xi^a}{\partial \nu^b} = \begin{pmatrix} 1 & 0 & 0 \\ 0 & \cos \alpha & -\sin \alpha \\ 0 & \sin \alpha & \cos \alpha \end{pmatrix}.$$

The determination of  $\cos \gamma_A$  and  $\sin \gamma_A$  is the only remaining problem. The Fig. 4 indicates

$$\cos \gamma_A = (1, 0) \cdot \mathbf{n} \text{ and } \sin \gamma_A = \pm |(1, 0) \times \mathbf{n}|.$$

From analytical geometry we have

$$n^1 = \frac{b_t^2}{\sqrt{(b_t^1)^2 + (b_t^2)^2}} \text{ and } n^2 = \frac{-b_t^1}{\sqrt{(b_t^1)^2 + (b_t^2)^2}}, \text{ where } b_t^a = \frac{\partial b^a}{\partial x^2}$$

and

$$b^1 = (a + x^1) \cos x^2, \quad b^2 = (b + x^1) \sin x^2.$$

Performing the derivatives leads to

$$\mathbf{n} = \frac{1}{d} \begin{pmatrix} (b + x^1) \cos x^2 \\ (a + x^1) \sin x^2 \end{pmatrix}, \quad d = \sqrt{(a + x^1)^2 \sin^2 x^2 + (b + x^1)^2 \cos^2 x^2}$$

and hence

$$\cos \gamma_A = \frac{b + x^1}{d} \cos x^2, \quad \sin \gamma_A = \frac{a + x^1}{d} \sin x^2.$$

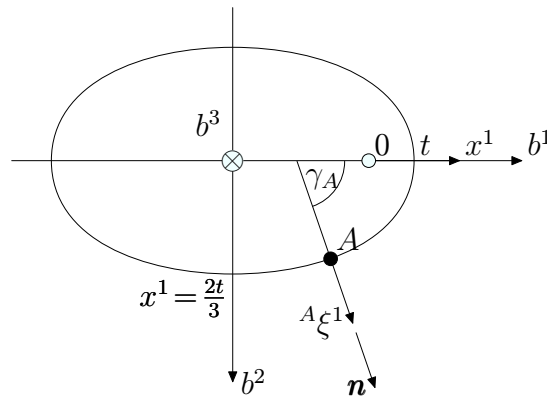

Fig. 4. Normal to ellipse

From the said above, we have

$$\hat{u}_a = \arg \min_{u_b \in \mathbb{U}} \Pi(u_c), \quad \Pi(u_a) = a(u_a) - l(u_a)$$

with

$$a(u_a) = \frac{1}{2} \int_{\Omega} E^{abcd} \varepsilon_{ab}(u_a) \varepsilon_{cd}(u_a) d\Omega, \quad l(u_a) = \int_{\Omega} p^a u_a d\Omega + \int_{\partial_t \Omega} t^a u_a d\Gamma.$$

Let us limit ourselves to the case of small deformations, then

$$\varepsilon_{ab} = \frac{1}{2} (\nabla_a u_b + \nabla_b u_a), \quad \nabla_a u_b = \partial_a u_b - \Gamma_{ab}^c u_c.$$

That means

$$\varepsilon_{ab}^x = \frac{1}{2}(\partial_a^x u_b + \partial_b^x u_a - 2 \Gamma_{ab}^c u_c), \quad \Gamma_{ab}^c u_c = \Gamma_{ab}^1 u_1 + \Gamma_{ab}^2 u_2 + \Gamma_{ab}^3 u_3.$$

Using GNU MAXIMA<sup>2</sup> we readily obtain (in the coordinate system  $x^a$ )

$$\Gamma_{ab}^1 = \frac{1}{J} \begin{pmatrix} 0 & (a-b) \cos x^2 \sin x^2 & 0 \\ (a-b) \cos x^2 \sin x^2 & -((x^1)^2 + x^1(a+b) + ab) & 0 \\ 0 & 0 & 0 \end{pmatrix},$$

$$\Gamma_{ab}^2 = \frac{1}{J} \begin{pmatrix} 0 & 1 & 0 \\ 1 & (a-b) \cos x^2 \sin x^2 & 0 \\ 0 & 0 & 0 \end{pmatrix}, \quad \Gamma_{ab}^3 = 0,$$

where

$$J = (b-a) \cos^2 x^2 + x^1 + a.$$

Now, as

$$E^{abcd} = E^{bacd}$$

we can replace  $\varepsilon_{ab}^x$  with  $\partial_a^x u_b - \Gamma_{ab}^c u_c$  and write the total potential energy at the form

$$a = \frac{1}{2} \int_{\Omega} \left( \partial_a^x u_b - \Gamma_{ab}^p u_p \right) E^{abcd} \left( \partial_c^x u_d - \Gamma_{cd}^p u_p \right) \left| g_{ab} \right|^{\frac{1}{2}} d^3 x.$$

The elasticity tensor at the  $x$ -coordinates

$$E^{abcd} = \frac{\partial x^a}{\partial \nu^i} \frac{\partial x^b}{\partial \nu^j} \frac{\partial x^c}{\partial \nu^k} \frac{\partial x^d}{\partial \nu^l} E^{ijkl}$$

can be very easily performed in GNU OCTAVE<sup>3</sup> syntax as (the following examples of the codes are presented just to demonstrate the simplicity of the numerical realisation of the solution)

```
xnu=xb*bxi*xinu
Ex=kron(xnu,xnu)*Enu*kron(xnu',xnu')
```

Let us approximate the solution by a Fourier series that satisfies boundary conditions

$$x^3 = 0 : u_1 = 0, u_2 = 0, u_3 = 0.$$

Such series is, for example,

$$u_1^x = \sum_{j,k,m=-K}^K a_1^{jkm} x^3 e^{i(jx^1 \frac{2\pi}{\ell} + kx^2 + mx^3 \frac{2\pi}{\ell})},$$

$$u_2^x = \sum_{j,k,m=-K}^K a_2^{jkm} x^3 e^{i(jx^1 \frac{2\pi}{\ell} + kx^2 + mx^3 \frac{2\pi}{\ell})},$$

<sup>2</sup><http://sourceforge.net/projects/maxima>

<sup>3</sup><http://www.octave.org/>

$$u_3^x = \sum_{j,k,m=-K}^K a_3^{jkm} x^3 e^{i(jx^1 \frac{2\pi}{t} + kx^2 + mx^3 \frac{2\pi}{t})},$$

where, ideally,  $K = \infty$  and, practically,  $K = 3$ .

Provided that we denote

$$u_{1,2,3}^x = \sum a_{1,2,3} \varphi \quad (\varphi = x^3 \phi)$$

we can write

$$\partial_b^x u_a^x = \frac{\partial u_a^x}{\partial x^b} = \begin{pmatrix} \sum a_1 \varphi ij \frac{2\pi}{t} & \sum a_1 \varphi ik & \sum a_1 (\varphi im \frac{2\pi}{t} + \phi) \\ \sum a_2 \varphi ij \frac{2\pi}{t} & \sum a_2 \varphi ik & \sum a_2 (\varphi im \frac{2\pi}{t} + \phi) \\ \sum a_3 \varphi ij \frac{2\pi}{t} & \sum a_3 \varphi ik & \sum a_3 (\varphi im \frac{2\pi}{t} + \phi) \end{pmatrix}.$$

As

$$\varphi = \varphi^{jkm} = x^3 e^{ijx^1 \frac{2\pi}{t}} \cdot e^{ikx^2} \cdot e^{imx^3 \frac{2\pi}{t}}$$

we can, in GNU OCTAVE syntax, write

```
j=(-3:1:3); k=(-3:1:3); m=(-3:1:3);
phi=x3*kron(kron(exp(i*j*x1*2*pi/t),exp(i*k*x2)),exp(i*m*x3*2*pi/ell));
ux=[phi,zeros(1,686);zeros(1,343),phi,zeros(1,343);zeros(1,686),phi]*A;
```

where A is a vector of unknown coefficients  $a_a^{jkl}$  and ux stands for

$$\mathbf{ux} = \begin{pmatrix} x \\ u_1 \\ x \\ u_2 \\ x \\ u_3 \end{pmatrix}.$$

Writing

$$\left\{ \frac{\partial u_a^x}{\partial x^b} \right\}_{ab} = \mathbf{B} \star \mathbf{A}$$

the matrix B is computed very easily via a few lines of the syntax. As the part of the deformation gradient containing the Christoffel symbols

$$\Gamma_{ab}^c u_c^x = \Gamma_{ab}^1 u_1^x + \Gamma_{ab}^2 u_2^x + \Gamma_{ab}^3 u_3^x$$

is expressible in the form

$$\left\{ \Gamma_{ab}^p u_p^x \right\}_{ab} = \left\{ \Gamma_{ab}^1 \right\}_{ab} \star [\text{phi}, \text{zeros}(1, 686)] \star \mathbf{A} + \left\{ \Gamma_{ab}^2 \right\}_{ab} \star [\text{zeros}(1, 343), \text{phi}, \text{zeros}(1, 343)] \star \mathbf{A}$$

we may for the whole deformation gradient write

$$\left( \partial_a^x u_b^x - \Gamma_{ab}^p u_p^x \right) = (\mathbf{B} - \mathbf{Gam}) \star \mathbf{A}$$

where

```
J=(b-a)*(cos(x2))**2+x1+a;
G1=1/J*[0,(a-b)*cos(x2)*sin(x2),0;
(a-b)*cos(x2)*sin(x2),-(x1)**2+{x1}*(a+b)+a*b,0;0,0,0];
G2=1/J*[0,1,0;1,(a-b)*cos(x2)*sin(x2),0;0,0,0];
Gam=vec(G1')*[phi,zeros(1,686)]+vec(G2')*[zeros(1,343),phi,zeros(1,343)];
```



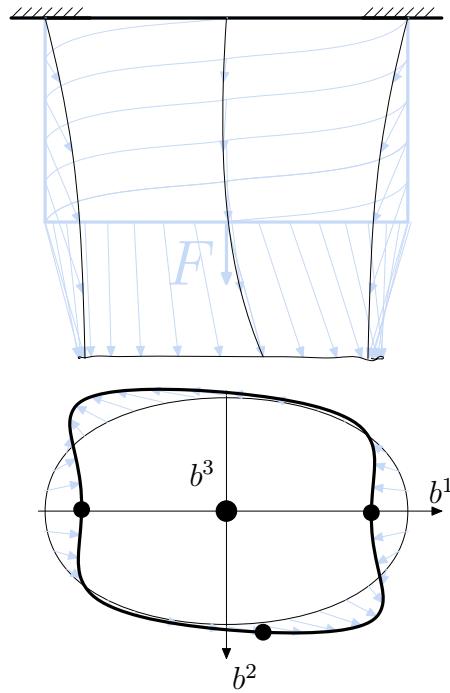

Fig. 5. deformation of the elliptic tube

### 3. Results

Thus, we can write for the elastic energy

$$a = \frac{1}{2} \mathbf{A}^T \mathbf{K} \mathbf{A}$$

with the stiffness matrix

$$K = \int_0^\ell \int_0^{2\pi} \int_0^t (\mathbf{B} - \text{Gam})' * \mathbf{E} \mathbf{x} * (\mathbf{B} - \text{Gam}) * \text{sqrt}(\det(\mathbf{g} \mathbf{x})) dx^1 dx^2 dx^3$$

where  $\mathbf{g} \mathbf{x} = (\mathbf{x} \mathbf{b} ** (-1))' * \mathbf{x} \mathbf{b} ** (-1)$  and the integration is performed numerically.

The work of the applied force

$$l = \int_S \frac{F_x}{S} u_3 dS$$

may be expressed as

$$l = \mathbf{P}' * \mathbf{A}$$

with

$$\mathbf{P} = \begin{pmatrix} \text{zeros}(363) \\ \text{zeros}(363) \\ \int_0^{2\pi} \int_0^t \frac{F_x}{S} \phi' * \text{sqrt}(\det(\mathbf{g} \mathbf{x})) dx^1 dx^2 \end{pmatrix},$$

the integration being once more performed numerically.

The resulting displacements,  $u_b$ , in the global coordinate system,  $b$ , obtained easily, at a given point  $(x_1, x_2, x_3)$ , via a few lines at GNU OCTAVE syntax

```
A=K**(-1)*P
phi=x3*kron(kron(exp(i*j*x1*2*pi/t),...
ux=real([phi,zeros(1,siz),zeros(1,...
xb=1/(a*(sin(x2))**2+b*(cos(x2))**2+...
ub=xb*ux
```

are demonstrated at Fig. 5.

All the calculations were performed using only the free software installed on an old laptop. The author considers this to be a proof of the great advantage of the demonstrated method.

## Acknowledgements

The work has been supported by the grant project GAČR 101-07-P496.

## References

- [1] S. S. Antman, *Nonlinear problems of elasticity*, Springer-Verlag, New York, 2005.
- [2] A. L. Cauchy, *Sur la condensation et la dilatation des corps solides*, Exercices de Mathematiques, 1827.
- [3] A. V. Cherkhaev, *Variational methods for structural optimization*, Springer, New York, 2000.
- [4] P. G. Ciarlet, *An introduction to differential geometry with applications to elasticity*, Springer-Verlag, Berlin, 2005.
- [5] P. G. Ciarlet, L. Gratie, C. Mardare, A nonlinear korn inequality on a surface, *Journal de mathématiques pures et appliquées* (2006), 1—22.
- [6] P. G. Ciarlet, F. Laurent, Continuity of a deformation as a function of its cauchy-green tensor, *Archive for Rational Mechanics and Analysis* 167 (2003), 255—269.
- [7] B. Dacorogna, *Direct methods in the calculus of variations*, Applied Math. Sciences, vol. 78, Springer-Verlag, Berlin, 1989.
- [8] A. E. Green, W. Zerna, *Theoretical elasticity*, Clarendon Press, Oxford, 1954.
- [9] A. E. H. Love, *Treatise on the mathematical theory of elasticity*, Cambridge university press, Cambridge, 1927.
- [10] D. Lovelock, H. Rund, *Tensors, differential forms, and variational principles*, Dover Publications, Inc., New York, 1989.
- [11] T. Mareš, Locally orthotropic material—the foundation of tissue mechanics, *Bulletin of Applied Mechanics* 7 (2006), 151–157.
- [12] S. G. Mikhlin, *Variational methods in mathematical physics*, The Macmillan Co., New York, 1964.
- [13] J. L. Synge, A. Schild, *Tensor calculus*, Dover Publications, Inc., New York, 1978.
- [14] R. M. Wald, *General relativity*, University of Chicago Press, Chicago and London, 1984.
- [15] S. Waner, *Introduction to differential geometry and general relativity*, Department of Mathematics, Hofstra University, 2005.
- [16] K. Washizu, *Variational methods in elasticity and plasticity*, 2nd ed., Pergamon Press, Oxford, 1975.