

# HTS TRANSFORMER – OPTIMIZATION OF WINDING LOSSES

ING. MILAN KRASL, PH.D.

**Abstract:** *This paper deals with a calculation of losses in winding of the superconducting transformer 1MVA. The idea of this usage originated in the SKODA Research Ltd., Pilsen. 5kVA model of this transformer was made with co-operation AS CR, UWB Pilsen, MFF Prague, Skoda Research Ltd., Pilsen with the financial support GaCR. AC loss is one of the important parameters in HTS (High Temperature Superconducting) AC devices. The calculation of losses in winding of the superconducting transformer is realized by the finite element method. The basic section of this article is 2D model of the transformer in FEMM and then calculation of the losses in the winding. The next part includes a suggestion to the restriction of the losses in this winding. The summary knowledge is contain in the conclusion the of the paper.*

**Key words:** *HTS transformer, FEM, AFR's, permeable cylinder.*

## INTRODUCTION

HTS (High Temperature Superconducting) transformer is one of the most important elements composing the total superconducting power network [1]. In general, the HTS windings of the transformer are immersed in the liquid nitrogen whose boiling temperature is 77 K at atmospheric pressure. But BSCCO wire that is generally used for HTS wire in these days has not enough current capacity at 77 K to directly apply to the large capacity HTS power devices. So, in many cases they used to cool it down below the 77 K by sub-cooling because operating the HTS wires at lower temperature can increase the critical current, which means the maximum current capacity of the superconducting wire [2]. Considering windings of the large capacity HTS transformer, two kinds of HTS windings have been adopted so far. One is solenoid type winding and the other is pancake type one. In case that rated voltages of the transformer are high, the pancake type winding has lots of advantages such as good insulation and distribution of surge voltages and so on. But unfortunately, strong alternate magnetic field applied perpendicularly to the face of the BSCCO wire in the pancake winding causes very high AC loss as well as degradation of the critical current of the HTS windings of the transformer. This high AC loss is major serious problem of the HTS transformer with pancake type windings.

The critical current can be upgraded according to lowering the operating temperature, but the AC loss depends not only on the operating temperature but also on

the amount and geometric shape of the magnetic field applied to the BSCCO wire.

In the paper we performed a study for optimal design of the windings for HTS power transformer. The next part includes the restriction of the losses in this winding. The transformer is a core construction. We assumed that the capacity of the transformer is 1 MVA and the HTS windings are cooled by the liquid nitrogen. The calculation of AC loss was accomplished by 2-dimensional Finite Element Metod. The HTS transformers is new problematic and evolving – for example Sinkanzen rolling stock, 4MVA HTS transformer, fig. 1.[4]



Fig. 1. 4MVA HTS transformer

# 1 AC LOSSES IN WINDING

## 1.1 Transport current losses

The transport current losses without influence the outer magnetic field are. We suppose using the multifilamentary superconductor Bi2223. When the magnetic field is applied under an angle  $\alpha < 90^\circ$  the AC losses [3], [5] increase with the decreasing angle up to an order of the magnitude for  $\alpha = 0^\circ$ . Their computation, however, cannot be performed by analytical methods. On the other hand, various numerical models allow their modelling, but for engineering purposes it is important to have a formula in the form of

$$Q_{tot} = Q_{tot}(B_a, I_t, \alpha) \quad (1)$$

where  $B_a$  is the amplitude of the applied magnetic field,  $I_t$  amplitude of the field current and  $\alpha$  orientation of the magnetic field as follows from [2].

The engineering formula is derived term by term in the following sections. The AC losses may be divided into two parts

- a) Magnetisation losses
- b) Transport current losses

The total AC losses are obtained as

$$Q_{tot}(B_a, I_t, \alpha) = Q_m(B_a, \alpha) + Q_i(B_a, I_t, \alpha) \quad (2)$$

The total losses in the windings of the transformer are

$$\Delta P_V = 2\pi f \sum_{i=1}^N r_i Q_{tot,i} \text{ [W]} \quad (3)$$

where  $\Delta P$  denotes the total losses in the winding [W],  
 $Q_{tot,i}$  total losses in the  $i$ -th superconductor [W/m]  
 $r_i$  radius of the  $i$ -th superconductor [m]  
 $f$  frequency [Hz]

Further solution of the task requires the knowledge of distribution of the magnetic field  $B_a$ . This can be found numerically using a suitable FEM-based program.

The eddy current loss in a rectangular conductor is proportional to the frequency, the square of the field and the conductivity of the silver sheath,  $\sigma$ . This component of loss is small compared to the hysteresis loss and therefore will not be included in this initial design study. Eddy current loss will become important compared to the hysteresis loss if high field amplitudes and frequencies are used. In addition, it has become almost common practice now to include higher resistance alloys in superconducting sheaths to minimise the conductivity as much as possible which in turn reduces the magnitude of the induced eddy currents. The simplest technique is to incorporate a transpositioning of tapes within a bundled conductor. Another technique is to use transposed conductor with insulation on each tape, such as Roebel type conductor. This technique effectively interrupts the eddy current

path and reduces its magnitude in a way similar to insulated laminations in iron cores. In conventional transformers, these techniques effectively limit eddy current loss to less than 10% of the total losses.

## 2 THEORY OF MAGNETIC FIELD SOLUTION

The problems were solved as a magnetostatic problem. In this case, the magnetic field strength  $\mathbf{H}$  and flux density  $\mathbf{B}$  are defined by formulas

$$\nabla \times \mathbf{H} = \mathbf{J} \quad (4)$$

$$\nabla \times \mathbf{B} = 0 \quad (5)$$

and

$$\mathbf{B} = \mu \mathbf{H} \quad (6)$$

If the material is nonlinear (saturated iron), the permeability depends on  $\mathbf{B}$ . The magnetic flux density is defined by means of the vector potential as

$$\mathbf{B} = \nabla \times \mathbf{A} \quad (7)$$

This definition always satisfies (6) and hence the equation (5) can be rewritten as

$$\nabla \times \left( \frac{1}{\mu(\mathbf{B})} \nabla \times \mathbf{A} \right) = \mathbf{J} \quad (8)$$

## 3 OPTIMIZATION OF WINDING LOSSES

For optimization of losses in windings are designed

- Additional ferromagnetic rings
- Permeable cylinders

*Additional ferromagnetic rings* (AFR's), fig. 3., are designed to improve magnetic field distribution in the winding area. They are placed near the winding ends in the nitrogen vessel of the cryostat. The AFR's are laminated, no presence of inner short-circuit is permitted. The AFR's bring not only reduction of the radial field component but also elimination of stray field differences along the winding circumference. Both facts have a positive impact on the critical current.

Among the primary and the secondary windings the cylinder with permeability 4-6 [H.m<sup>-1</sup>] is puted. The *permeable cylinders* (PM's) have two major components. The first component is resin and second components are metallic dusts. The metallic dusts are fifty-fifty placed in the resin. A permeable cylinder overlaps the winding of the transformer. Design of 3D model of the transformer with permeable cylinders is at the figure 4. Permeable cylinders regulate magnetic flow all over longitude of the windings. This fact reduces losses, equations (1) – (3).

A combination of these parts was't speculated.

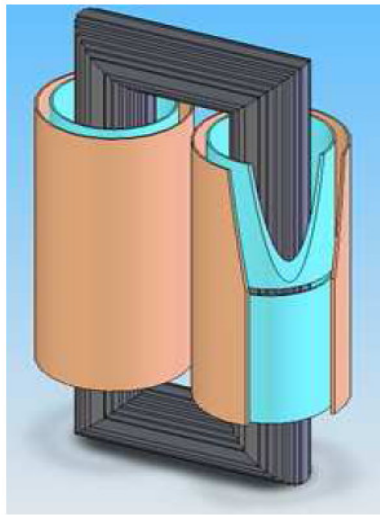

Fig. 2. HTS transformer

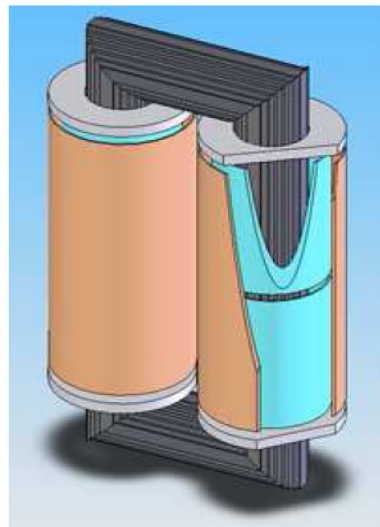

Fig. 3. HTS transformer with AFR's

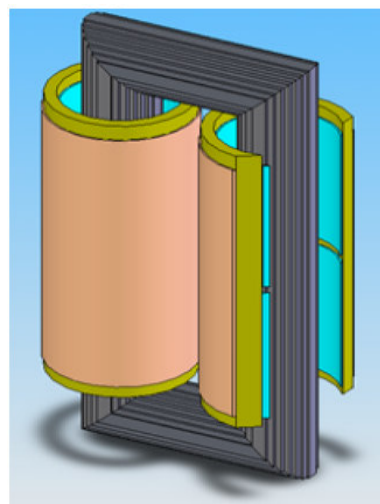

Fig. 4. HTS transformer with permeable cylinders

#### 4 RESULTS OF CALCULATIONS

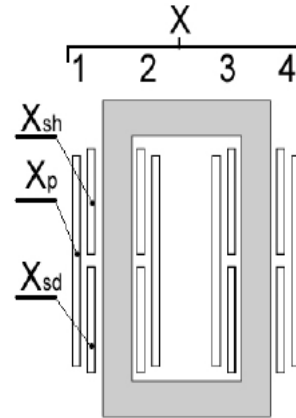

Fig. 5. 1MVA transformer model

Fig. 7a, b, c show examples of calculations – program FEMM. Fig. 4 is a detail of HTS transformer – permeable cylinder [3]. Fig. 5 is a 1MVA transformer model for FEM calculations.

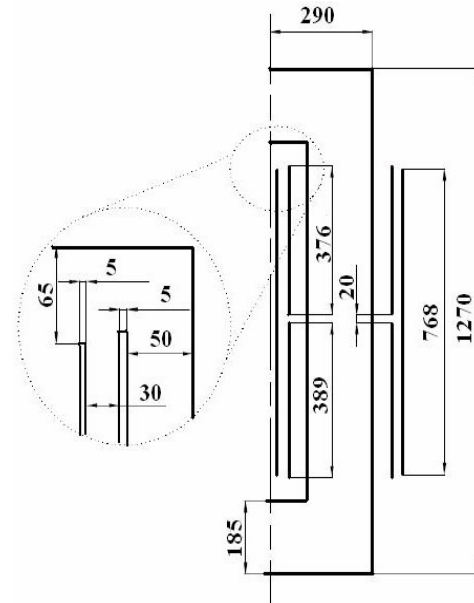

Fig. 6. Geometrical sizes of transformer

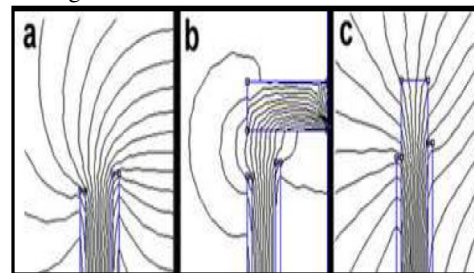
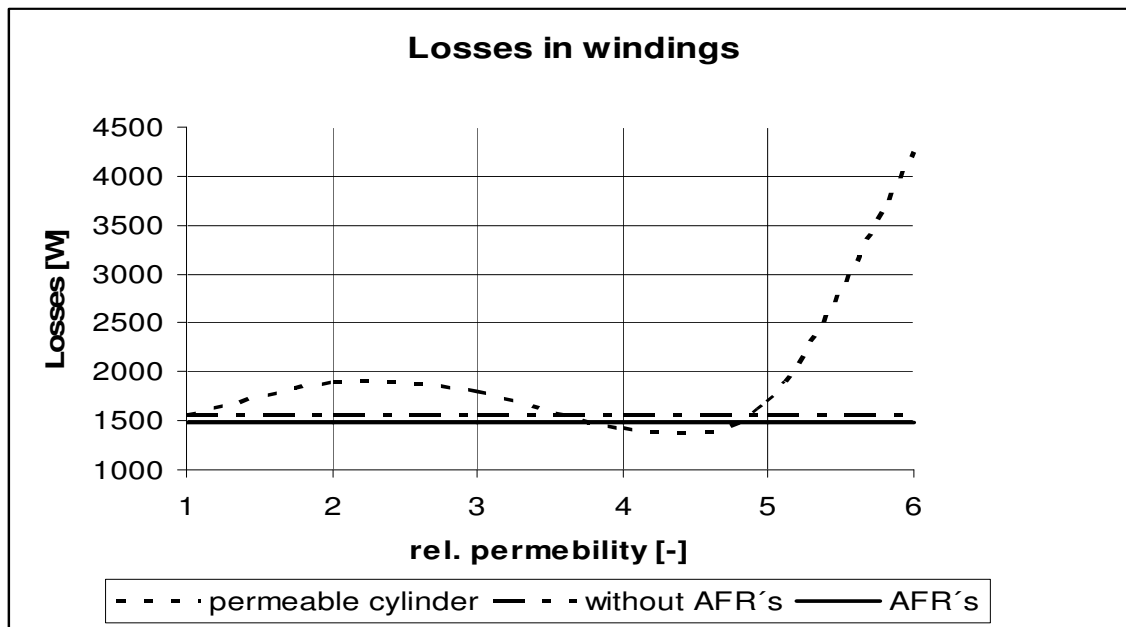

Fig. 7. A) section from FEMM without the ferromagnetic rings. B) with ferromagnetic ring C) with permeable cylinder

For calculation of losses in windings was created user's program which evaluated losses according to the equation (1) – (3). [2].



Graph. 1. Losses in windings

Graph 1. shows results of calculations. Losses in windings were calculated for 3 configurations – 1) HTS transformer with permeable cylinder 2) without AFR's 3) with AFR's.

## 5 REALISED MODEL

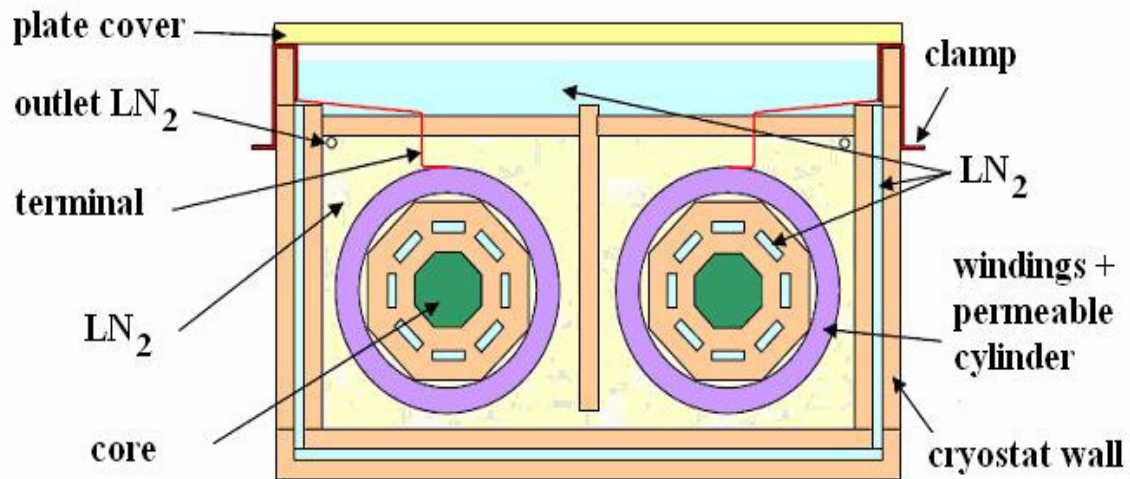

Fig. 8. 5kVA model of HTS transformer

5kVA model of this transformer was made with co-operation AS CR, UWB Pilsen, MFF Prague, Skoda Research Ltd., Pilsen with the financial support GaCR. Fig. 8. shows model of the HTS transformer, fig. 9., 10., 11. and 12. several parts of this transformer before work assembly.



Fig. 9. Primary and secondary coil



Fig. 10. Fault current limiter



Fig. 11. Superconducting wire coiling



Fig. 12. Completed cryostat

## 6 CONCLUSION

Reduction of the losses is performed by ferromagnetic rings and by permeable cylinder. In the first case the losses are reduced to about 5%. In the second case the losses are reduced to about 8% - permeable cylinders. The computer software FEMM makes possible solve the problem only in 2D this fact leads to simplification. Non-linearity magnetic circuit is possible to solved only for zero frequency. For better specification is need to used computing system which makes possible model in 3D. Results of measurements between 5kVA HTS transformer with permeable cylinder and without PM were not realised for construction finality, de bene esse.

## 7 REFERENCES

[1] KRASL, M. Calculation of superconducting traction transformer 1MVA and its cooling. *In* 2005 IEEE St. Petersburg PowerTech Proceedings. St. Petersburg :

Energy Systems Institute, 2005. pp. 1-4. ISBN 5-93208-034-0.

[2] RYBAR, J.; KRASL, M. Calculation of losses in windings of superconducting transformer. *In* Acta Technica CSAV. 2003, roč.2003, No.1, pp. 77-78, ISSN 0001-7043.

[3] Jelinek V. : Calculation of losses of superconducting winding of transformer. Dipl. work 2008.

[4] Kamijo H., Hata H. : Fabrication of Superconducting Traction Transformer for Railway Rolling Stock. *Journal of Physics: Conference Series* 43 (2006) 841-844. 7th European Conference on Applied Superconductivity.

[5] Rafajdus, P., Hrabovcová, V., Šušota, M., Vojenčíak, M. : Návrh supravodivého trakčného transformátora a jeho tepelná analýza, *International Conference on Electrical Machines*, Vilamoura, Portugal, 2008, September, 6.-9., AFC, str.: CD.

[6] Rafajdus, P., Hrabovcova, V., Labaj, J., Susota, M.: *Fluent Analysis of Traction Superconducting Transformer*, LVEM 2008, Slapanice-Brno, 2008, 11, AFC, str.: 98-101.